

EPHREM:
THE LEADING FRENCH MANUFACTURER
OF WOOD-FIRED OVENS

Since its founding in 1975, and with over 80,000 ovens sold in France and worldwide, Ephrem Manufacture designs and produces wood-fired ovens for private clients, bakers, and professionals in the food service industry.

Today, it unveils its first turnkey aesthetic and durable oven: The Flambeur.



WOOD-FIRED OVEN
MANUFACTURE
SINCE 1975



**A GASTRONOMIC TOOL AND
HEALTHY COOKING**

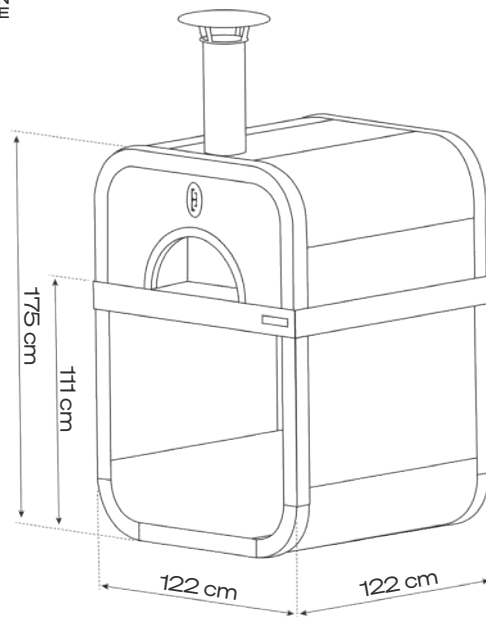

Internal diameter	90 cm	8 kg of bread per batch
H x W x D <small>(height x width x depth)</small>	Flambeur 1: 75 x 122 x 122 Flambeur 2: 175 x 122 x 122	2 pizzas Ø33cm per batch, or 40 per hour
Weight	Flambeur 1: 522 kg Flambeur 2: 564 kg	2 to 3 slow-cooked dishes Ø30 cm per batch
Maximum dimensions	122 x 122 cm	6 to 8 kg of wood per heating
Materials	Pozzolana, steel, terracotta, mineral wool insulation with vapor barrier	12 guests or more
Warranty	5 years	
Food safety certificate	Norme EN1388/1	

The Flambeur is proposed as a ready-to-assemble kit, with high-performance insulation and a contemporary thermocoated steel casing.

Available in two versions and customizable in various colors (upon request):

- The Flambeur 1: ready to install, without legs.
- The Flambeur 2: standalone module on legs.

Included | Black steel conduit and stainless steel chimney cap, insulated door, insulating materials, refractory clay slab floor + legs for The Flambeur 2, storage plate.

Optional | Cooking accessories, barbecue grill.

EPHREM
The Flambeur: the new
wood-fired oven is born



Images for illustrative purpose only



THE FLAMBEUR: A ONE-OF-A-KIND CULINARY EXPERIENCE



The Flambeur allows you to cook everything in the safety of a multifunctional enclosed hearth. A true cooking companion, this wood-fired oven offers remarkable versatility: breads, pizzas, slow-cooked dishes... The Flambeur is much more than just a cooking tool, it delivers a unique culinary experience, offering a fresh return to the roots of cooking.

SIMMER, COOK, GRILL, CONFIT, SMOKE, FLAMBÉ

A REAL WOOD-FIRED OVEN, WITH THE DESIGN TO MATCH

The style of The Flambeur makes it a true decorative element. Contemporary and modern, this wood-fired oven fits perfectly in your garden, on your terrace, or even indoors. The ideal companion for a kitchen full of authentic flavors, it is customizable with a wide range of colors.

- A true mass wood-fired oven: a refractory mass hearth and efficient insulation.
- For all types of cooking: barbecue, kamado, griddle, etc. The Flambeur is highly versatile.
- A unique design: contemporary and innovative.
- Easy installation: no masonry required.

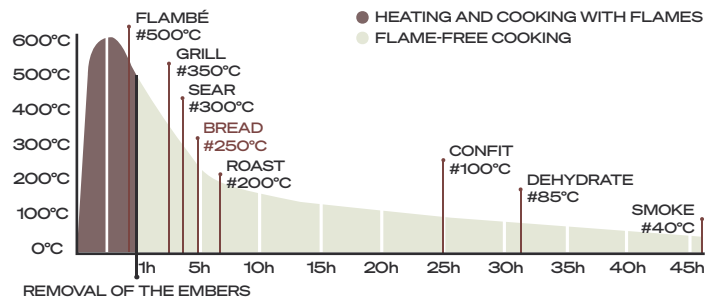

A HEARTH MADE FROM NATURAL MATERIALS, WITH EXCEPTIONAL INERTIA

A true wood-fired oven features a refractory mass hearth, ensuring genuine inertia. Designed for all types of wood-fired cooking, The Flambeur is equipped with a thermocoated steel casing, housing our iconic model: The Authentique Pizzaiolo. This model has been crafted from a highly refractory natural material: pozzolana, a volcanic soil from the Ardèche region.

